

Assembly instruction

Tower ALTA

This assembly instruction has been drawn up in accordance with SS-EN 1090-2 and should be used as guidance for trained installers with expertise in the field of erecting masts and towers.

Scanmast AB reserves the right to make changes, revise and interpret this instruction.

Mailing address:
Scanmast AB
Box 121
SE-792 22 Mora

Website
www.scanmast.se

Telephone
+46 250 292 00
FAX:
+46 250 140 78

CONTENTS:

1. CASTING FOUNDATION BOLTS IN TOWER FOUNDATION 3

 1.1 Section 11-14 3

 1.2 Section 15-17 4

 1.3 Section 18-19 5

 1.4 Section 20 6

2 ASSEMBLING SECTIONS 7

 2.1 Fully welded sections 20 and 19 8

 2.2 Section 193, 18/183..... 9

 2.3 Section 17/171..... 10

 2.4 Section 16/161..... 11

 2.5 Section 15/151..... 12

 2.6 Section 14/141..... 13

 2.7 Section 13/131, 12/121, 11/111 14

3 ASSEMBLING PARTS..... 15

 3.1 Section joint 15

 3.2 Ladder bracket 707929 17

 3.3 Ladder bracket 707930 18

 3.4 Cover plate section 20 18

 3.5 Ladder joint..... 19

4 ERECTING THE TOWER..... 19

 4.1 Erecting tower having completely assembled it on the ground..... 20

 4.2 Joints between base plates and section 11-17 20

5. UNDERCASTING BASE PLATES..... 22

 5.1 Warranty conditions 22

 5.2 Section 11-17 22

 5.3 Section 18-19 22

 5.4 Section 20 22

6. SPECIFICATIONS 23

 6.1 Torque for tightening screw joints (Does not apply to flange joints between sections!) 23

 6.2 Torque for tightening foundation bolts 23

 6.3 Locking with punch mark 23

 6.4 Weight specifications..... 24

7. PROPOSAL FOR INSPECTION PLAN 25

1. CASTING FOUNDATION BOLTS IN TOWER FOUNDATION

1.1 Section 11-14

Screw M12x40
Washer 13x24x7
Nut M12

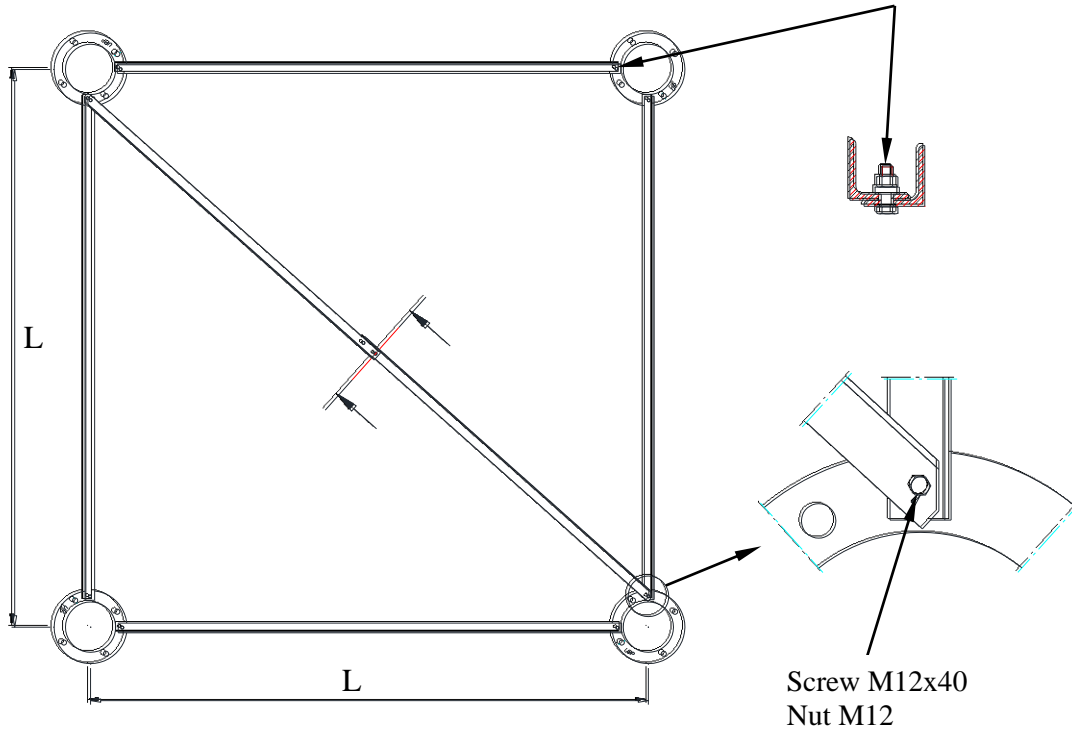

Foundation bolt



Fixing template Part No.	Section	L mm
712670	11	4820
711497	12	4360
711500	13	3900
711503	14	3440

1. Place and level the fixing template on the casting mould. Turn the "UP" marking on the plate so that it faces upwards.
2. Attach the foundation bolts to the fixing template with the ends marked yellow facing upwards.
3. Check that the foundations bolts are protruding 190 mm above the surface of the foundation.
4. Tighten the top and bottom nuts against the fixing template.

See separate drawing for further instructions regarding casting.

1.2 Section 15-17

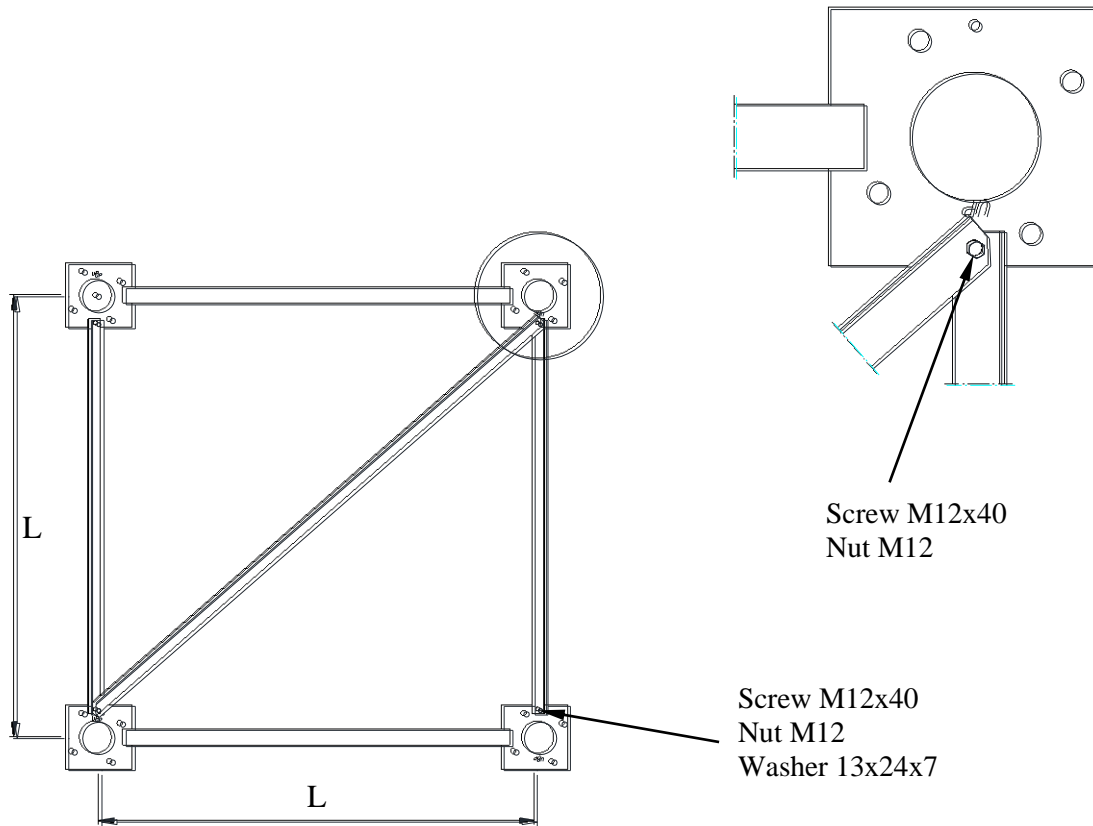

Foundation bolt



Fixing template Part No.	Section	L mm
711514	15	2980
715700	16	2520
715701	17	2060

1. Place and level the fixing template on the casting mould. Turn the "UP" marking on the plate so that it faces upwards.
2. Attach the foundation bolts to the fixing template with the ends marked yellow facing upwards.
3. Check that the foundation bolts are protruding 190 mm above the surface of the foundation.
4. Tighten the top and bottom nuts against the fixing template.

See separate drawing for further instructions regarding casting.

1.3 Section 18-19

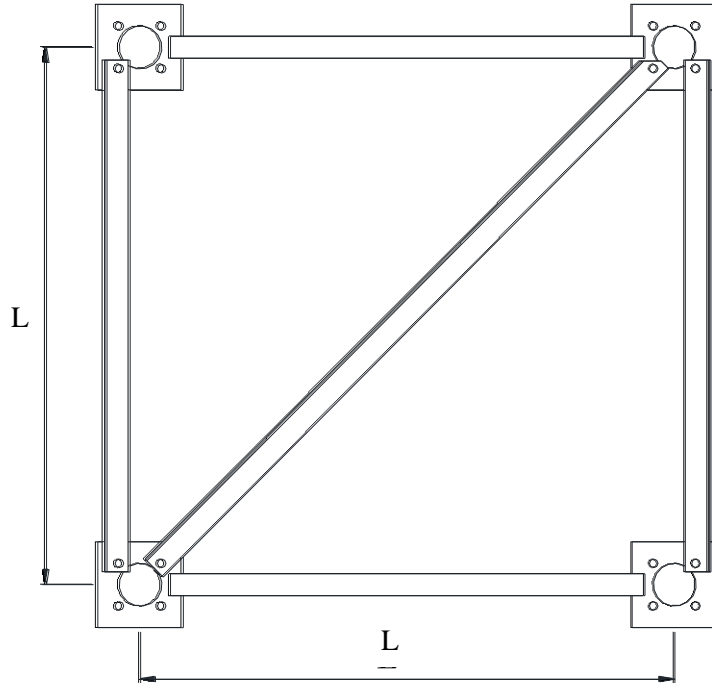

Foundation bolt



Fixing template Part no.	Section	L mm
719785	18	1600
711166	19	1250

1. Place and level the fixing template on the casting mould.
2. Attach the foundation bolts to the fixing template with the ends marked yellow facing upwards.
3. Check that the foundation bolts are protruding 170 mm above the surface of the foundation.
4. Tighten the top and bottom nuts against the fixing template.

See separate drawing for further instructions regarding casting.

1.4 Section 20

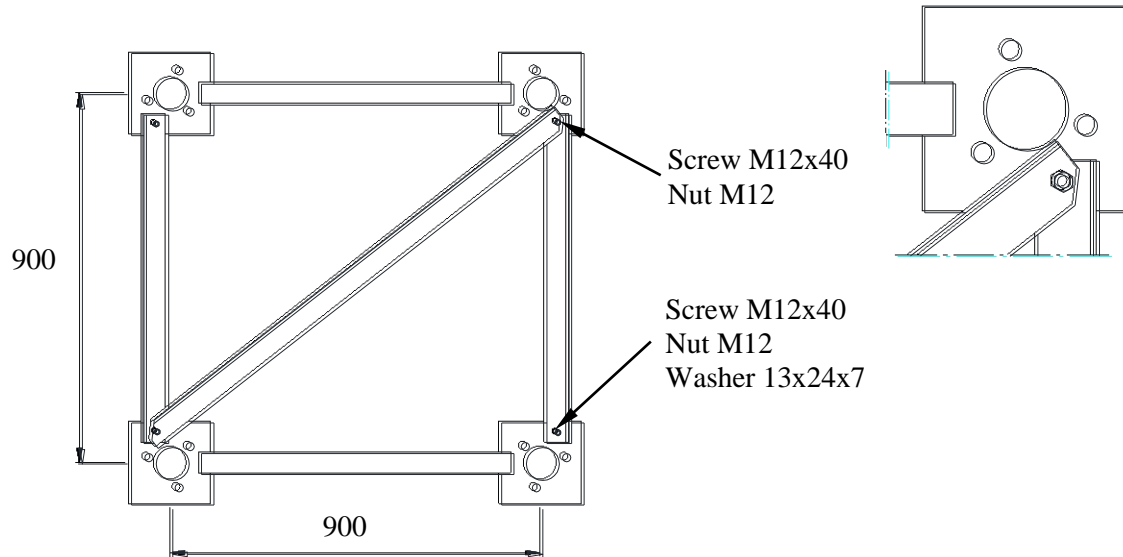

Foundation bolt

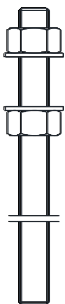

Fixing template	Section
Part no.	
711167	20

1. Place and level the fixing template on the casting mould.
2. Attach the foundation bolts to the fixing template with the ends marked yellow facing upwards.
3. Check that the foundation bolts are protruding 110 mm above the surface of the foundation.
4. Tighten the top and bottom nuts against the fixing template.

See separate drawing for further instructions regarding casting.

2 ASSEMBLING SECTIONS

The easiest way to erect the tower is with a mobile crane once it is fully assembled horizontally on the ground. These instructions assume that sections 19 and 20 are welded and that other sections are assembled on site. The supports should be levelled to avoid the tower twisting.

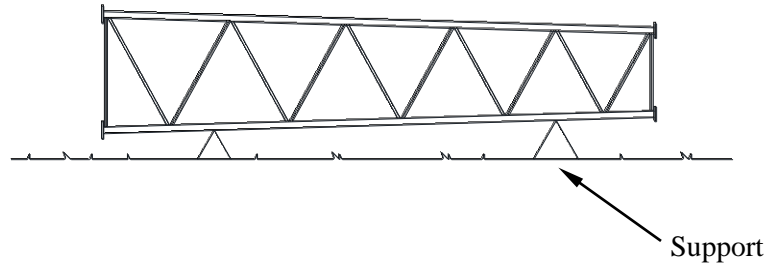

General procedure (assembly instructions for each section are set out in the following pages)

1. Assemble the welded sections.
2. Fit the lower two legs for section 18 to the bottom of section 19.
3. Fit the diagonal which is closest to the higher section which is already completed and proceed with the diagonals "downwards". Create a "floor" in this way.
4. Assemble the two remaining legs with diagonals in the same way on their own supports.
5. Having completed the unit consisting of 2 legs with intermediate diagonals, lift it into position and connect together with section 19.
6. Fit the diagonals in the two remaining sides of the section starting from the top end of the section.
7. Tighten the screw joints for the diagonals with torque. Tighten the screw joints in the section joints with torque and tighten angles according to instructions on pages 15-16.
8. Repeat the above procedure section by section down the tower.
9. Leave the final diagonals closest to the foundation undone until the tower has been placed on the foundation.

Marking

The undersides of the bottom joining flanges on the legs are marked with section numbers. The diagonals are numbered and the marking should be facing upwards.

2.1 Fully welded sections 20 and 19

The fully welded sections shall have the marking on the underside of the joining flanges facing downwards. The direction of the bottom diagonal is then obliquely up to the right (when viewed from the outside of the section).

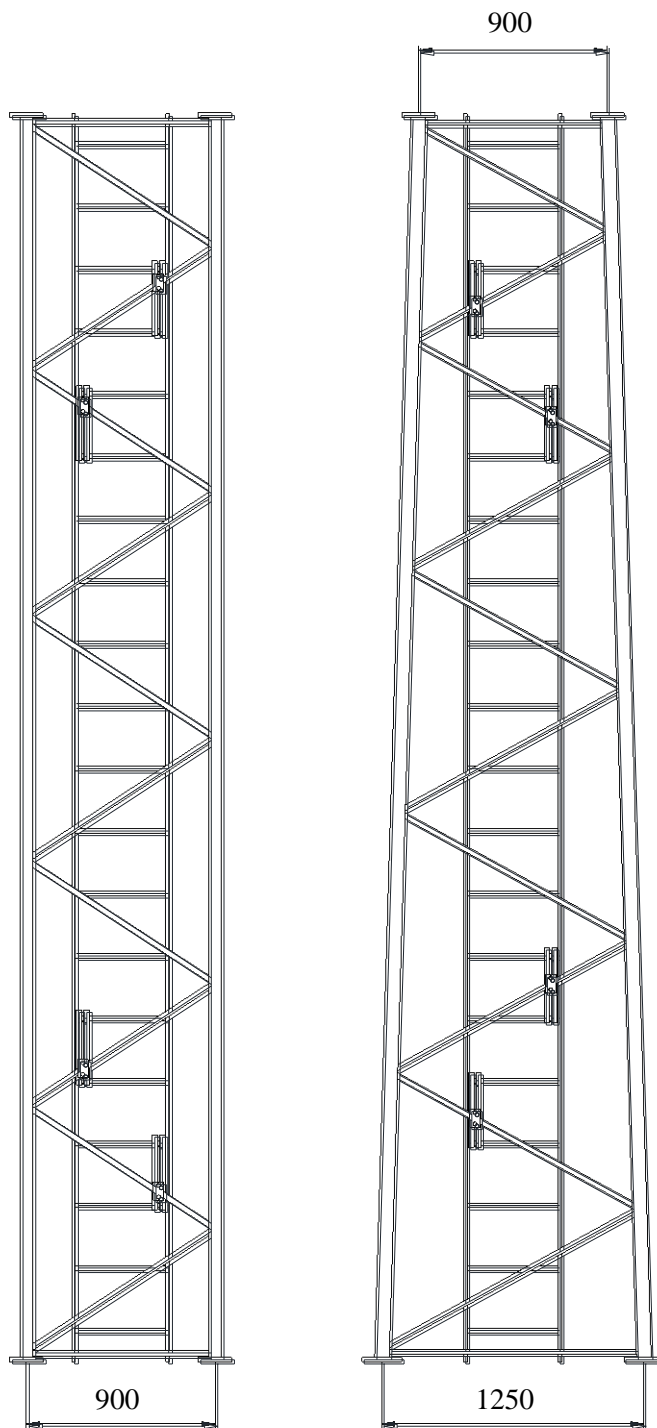

2.2 Section 193, 18/183

All diagonals are marked 190.

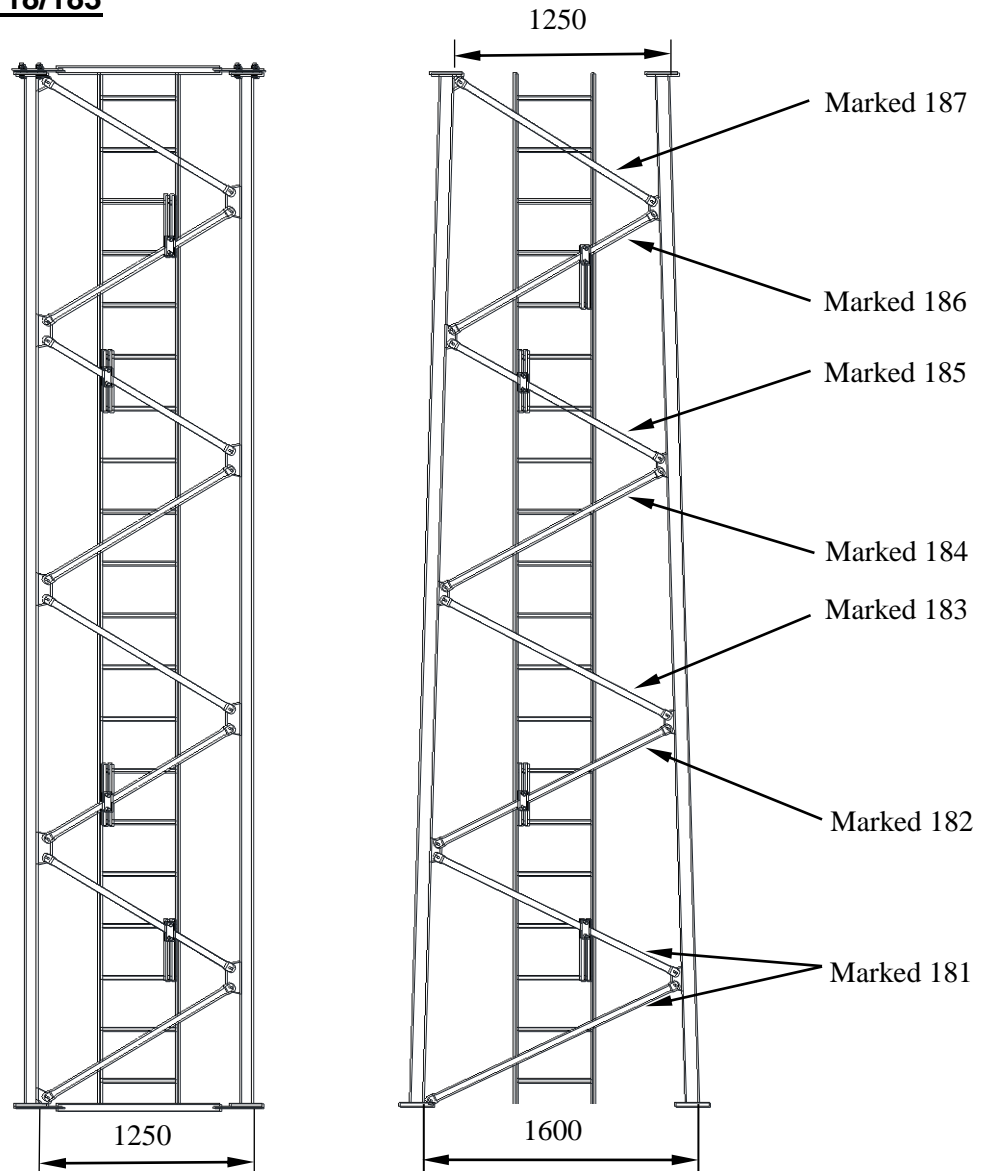

Horizontal bracing to be fitted between section 193 and 18.

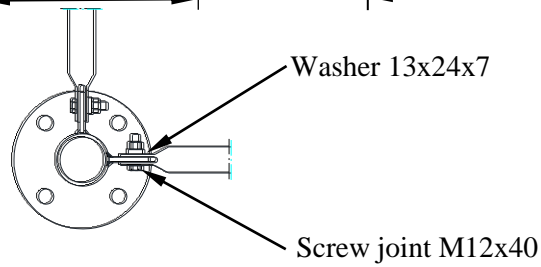

M12 nuts to be tightened with 87 Nm. Assembly instruction for ladder page 18.

2.3 Section 17/171

Horizontal bracing to be fitted between section 17 and 18.

Diagonal cross, section 17

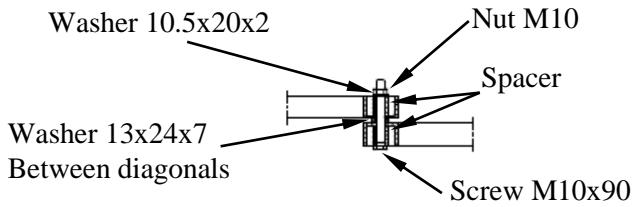

Diagonal cross, section 171

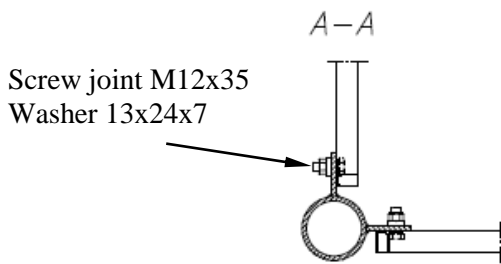
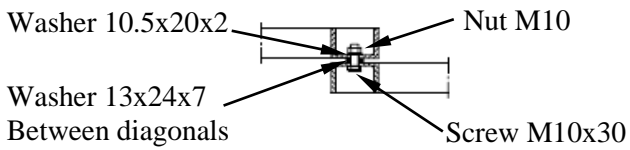

Section 171

Screw joint M12x35
Washer 13x24x7

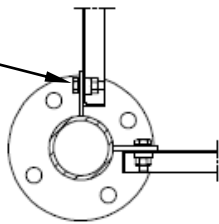

Section 17

Screw joint M12x55
Spacer

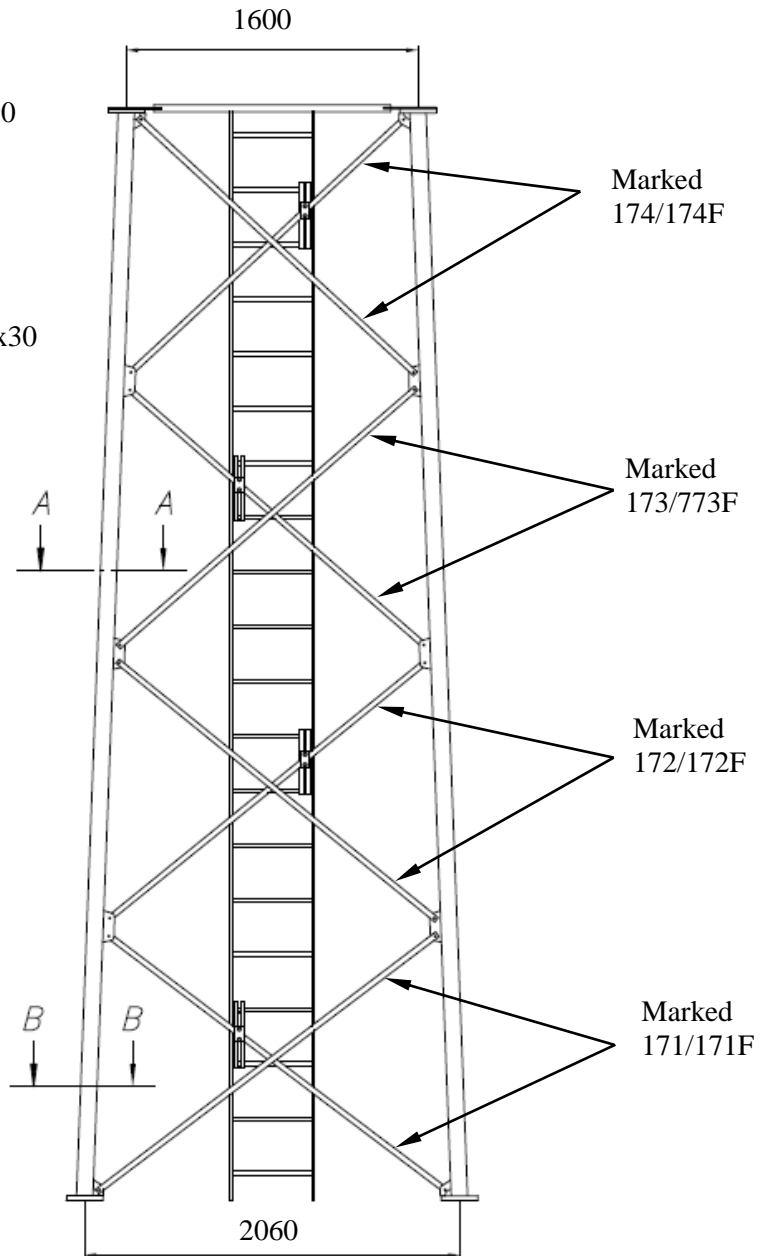
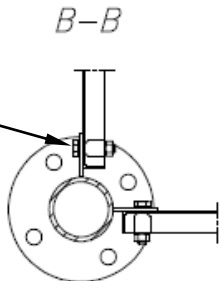

Note that the diagonal in the bottom left corner must be placed to the outside of the diagonal lug, and that the diagonal screws at the very bottom of the section are to be turned the opposite way to the others so that there is access to tighten the flange joints, and that spacer 101082 replaces the washers there.

Nuts M10 are tightened with 50 Nm, M12 with 87 Nm. Assembly instruction for ladder page 17-18.

2.4 Section 16/161

Diagonal cross, section 16

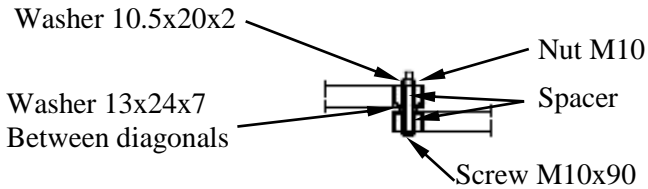

Diagonal cross, section 161

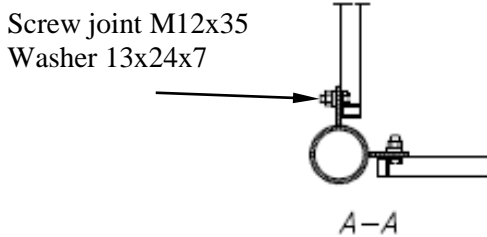
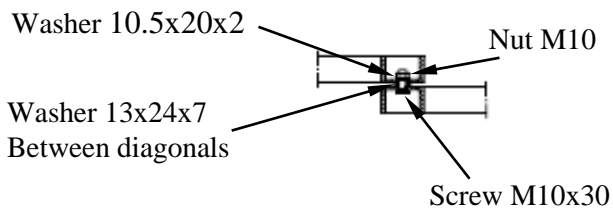

Section 161

Screw joint M12x35
Washer 13x24x7

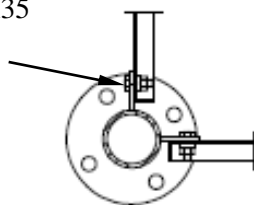

Section 16

Screw joint M12x55
Spacer

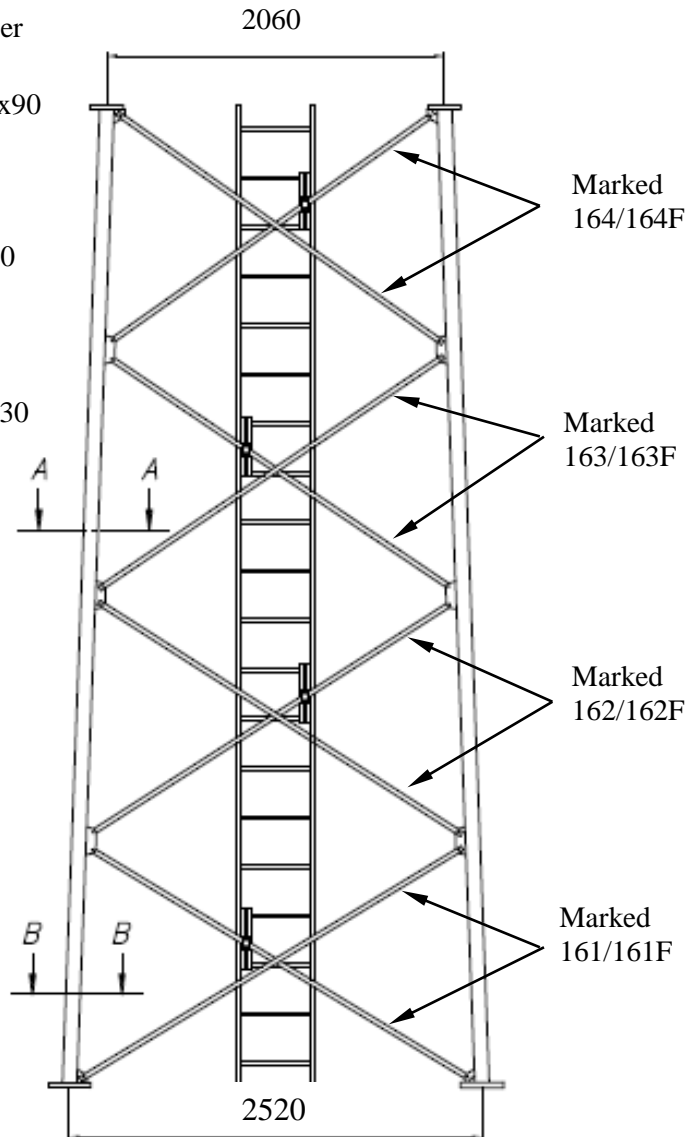
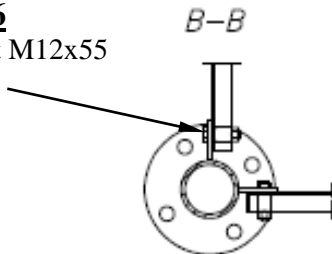

Note that the diagonal in the bottom left corner shall be placed to the outside of the diagonal lug, and that the diagonal screws at the very bottom and very top of the section are to be turned the opposite way to the others so that there is access to tighten the flange joints, and that spacer 101082 replaces the washers there.

Nuts M10 are tightened with 50 Nm, M12 with 87 Nm. Assembly instruction for ladder page 17-18.

2.5 Section 15/151

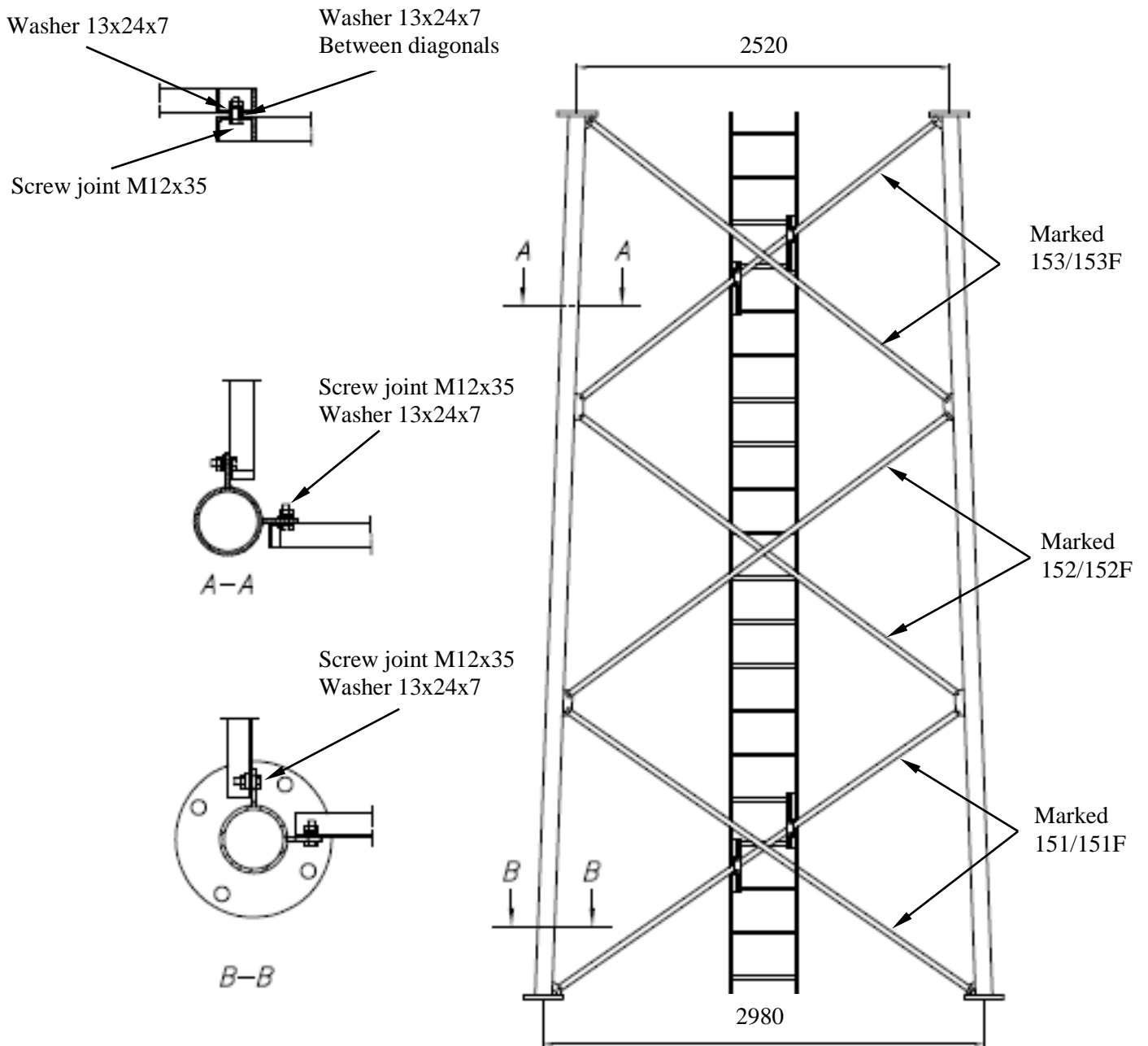

Note that the diagonal in the bottom left corner shall be placed on the inside of the lug, in distinction from the other sections, and that the diagonal screws at the bottom of the section are to be turned the opposite way to the others so that there is access to tighten the flange joints. M12 nuts to be tightened with 87 Nm. Assembly instruction for ladder page 18.

2.6 Section 14/141

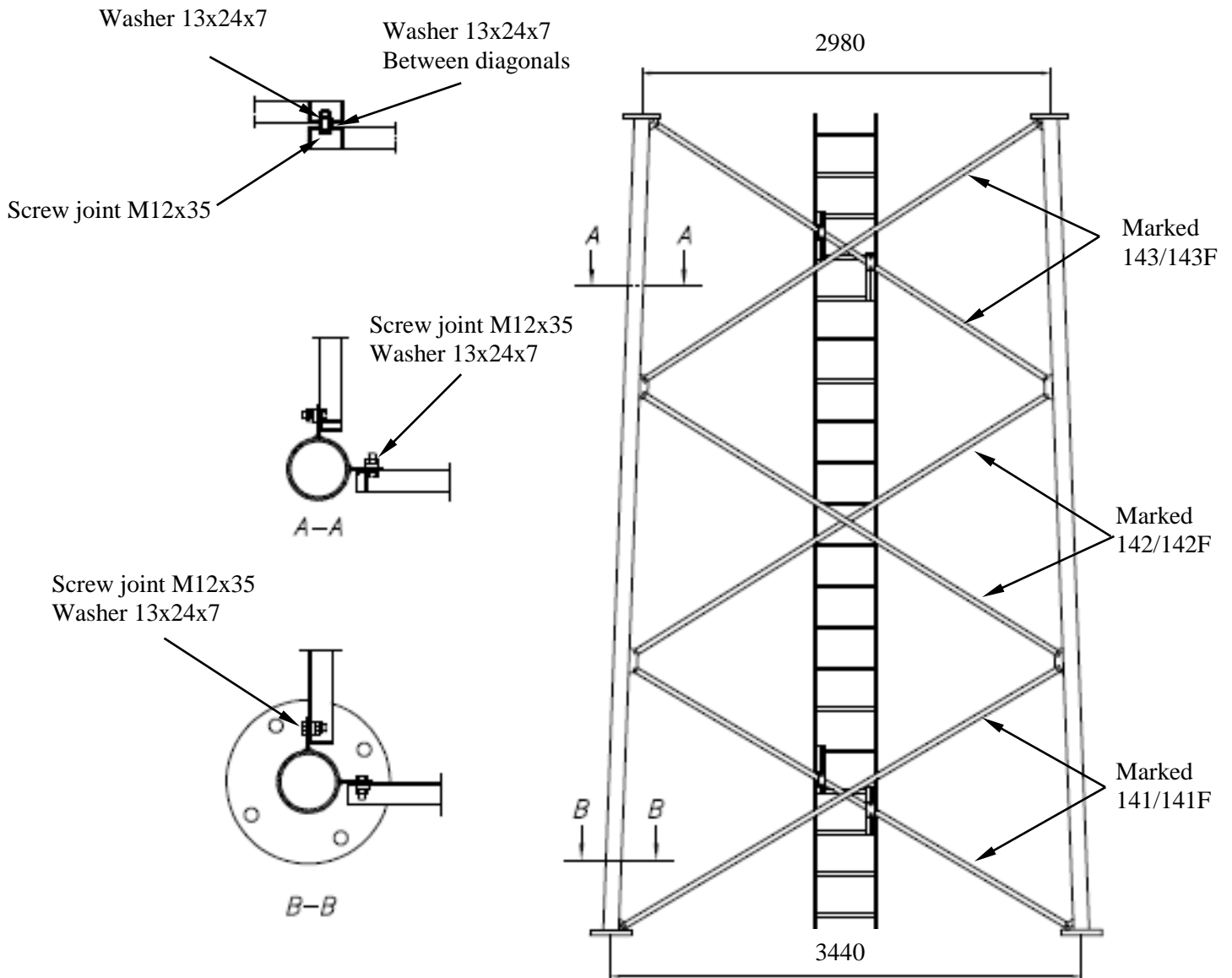

Note that the diagonal in the bottom left corner shall be placed on the outside of the diagonal lug, and that the diagonal screws at the bottom of the section are to be turned the opposite way to the others so that there is access to tighten the flange joints.

M12 nuts to be tightened with 87 Nm. Assembly instruction for ladder page 18.

2.7 Section 13/131, 12/121, 11/111

The sections 11/111, 12/121 and 13/131 should be stabilised diagonally using, for example, lashing straps, to avoid handling damage during assembly/lifting.

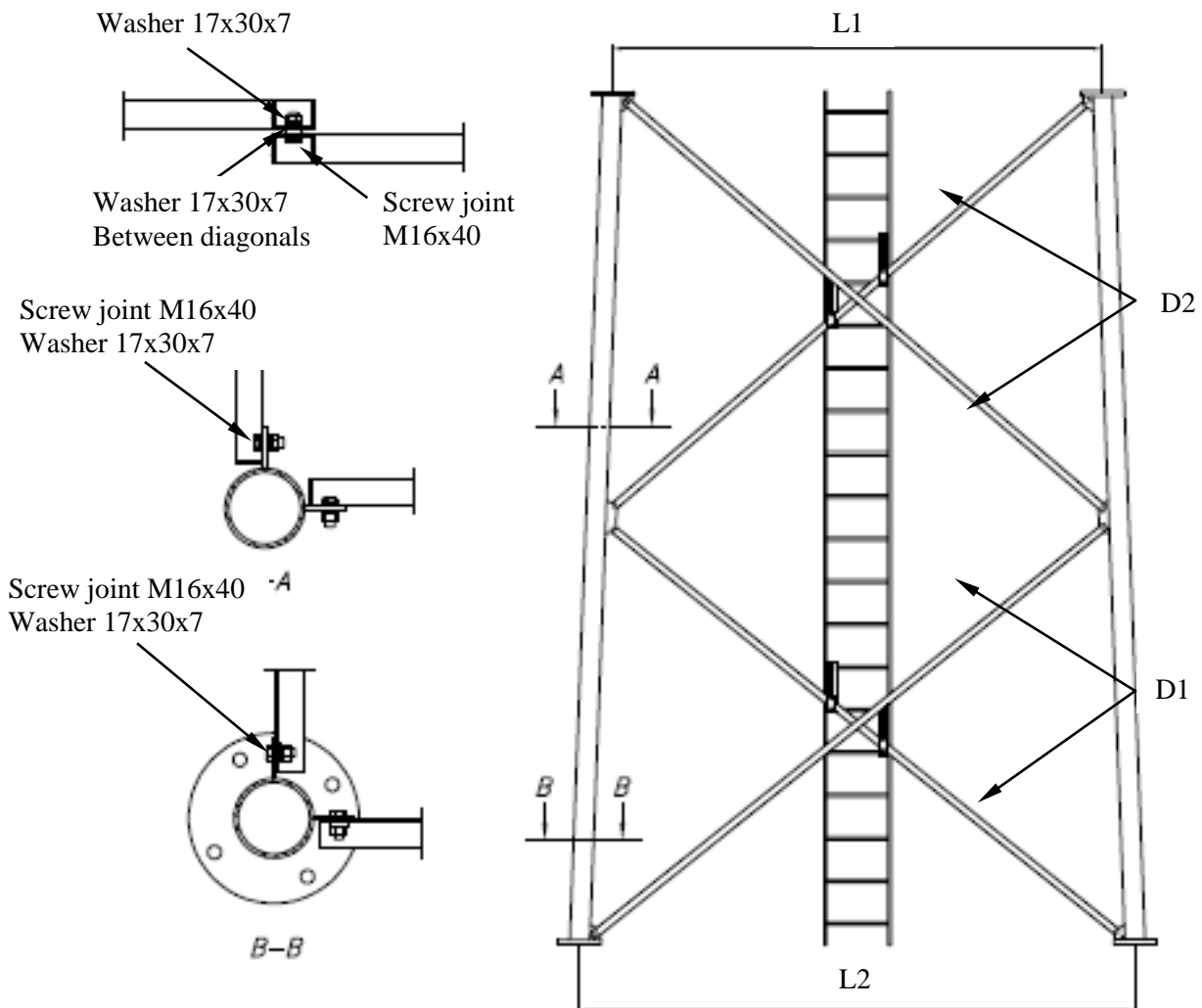

	L1 mm	L2 mm	D1 marking	D2 marking
<u>Section 13/131</u>	3440	3900	131	132
<u>Section 12/121</u>	3900	4360	121	122
<u>Section 11/111</u>	4360	4820	111	112

Note that the diagonal in the bottom left corner shall be placed on the outside of the diagonal lug, and that the diagonal screws at the bottom of the section are to be turned the opposite way to the others so that there is access to tighten the flange joints.

M12 nuts to be tightened with 211 Nm. Assembly instruction for ladder page 18.

3 ASSEMBLING PARTS

3.1 Section joint

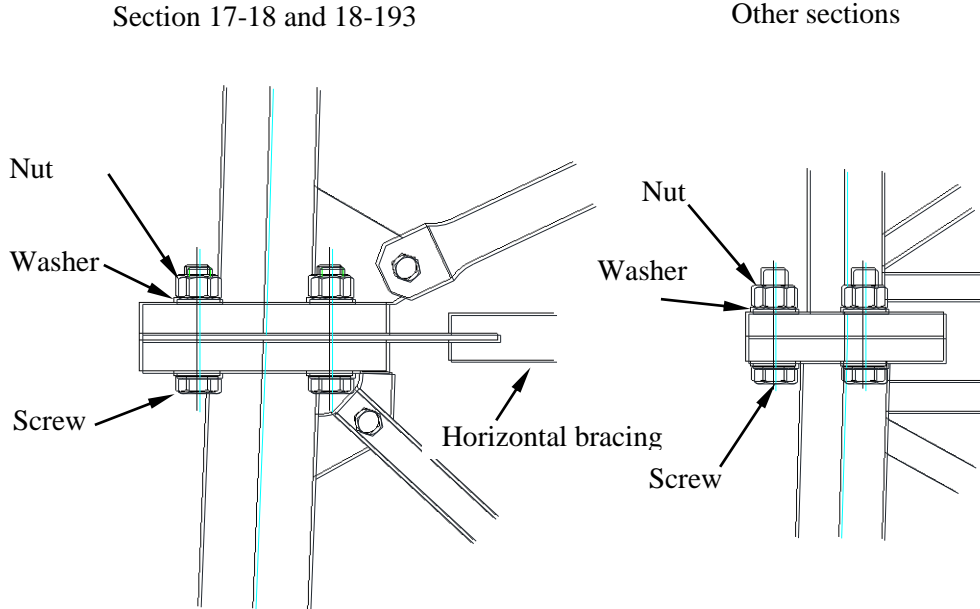

Tightening method HR assembly according to SS-EN 1090-2

The flange joints have a different type of screw joint and tightening method than the other joints. The screw joint has a tested friction between screw and nut and must not be further lubricated.

It is important to remember to keep the screw joint in its bag for as long as possible in order to avoid the lubricant being washed away by rain etc.

When tightening, first tighten all nuts in the joint to the torque indicated in the table.

Joint	Screw joint	Part No.	Tightening torque
11-12	HR 24x110 8.8/8 galvanized	100862	560 Nm
12-13	HR 24x110 8.8/8 galvanized	100862	560 Nm
13-14	HR 24x110 8.8/8 galvanized	100862	560 Nm
14-15	HR 22x100 8.8/8 galvanized	100867	350 Nm
15-16	HR 22x100 8.8/8 galvanized	100867	350 Nm
16-17	HR 20x 90 8.8/8 galvanized	100871	230 Nm
17-18	HR 20x 90 8.8/8 galvanized	100871	230 Nm
18-19	HR 20x 80 8.8/8 galvanized	100875	230 Nm
19-20	HR 20x 80 8.8/8 galvanized	100876	230 Nm
20-20	HR 20x 80 8.8/8 galvanized	100876	230 Nm

The position of the nut relative to the bolt threads shall be marked after the first step, using a marking crayon or marking paint, so that the final rotation of the nut relative to the thread in this second step can be easily determined.



0°

Tighten all nuts by a further 60° to obtain the correct pre-load in the joint.



60°

3.2 Ladder bracket 707929

Fits in sections with diagonals up to and including 30 mm. Set consisting of 4 x ladder brackets positioned according to picture of respective section.

If cable supports fitted with hooks around the rungs are to be used, the ladder bracket must be fitted 25 mm from the ladder pole.

Assemble the ladder with holes 9 mm in the side profile downwards in the section.

Position the clamp around the rung with accompanying screw in its outermost position (to the right in the left hand picture below) to avoid protruding edges for climbers.

Tighten M10 nut sufficiently without bending the plates.

Then secure all nuts with punch marks.

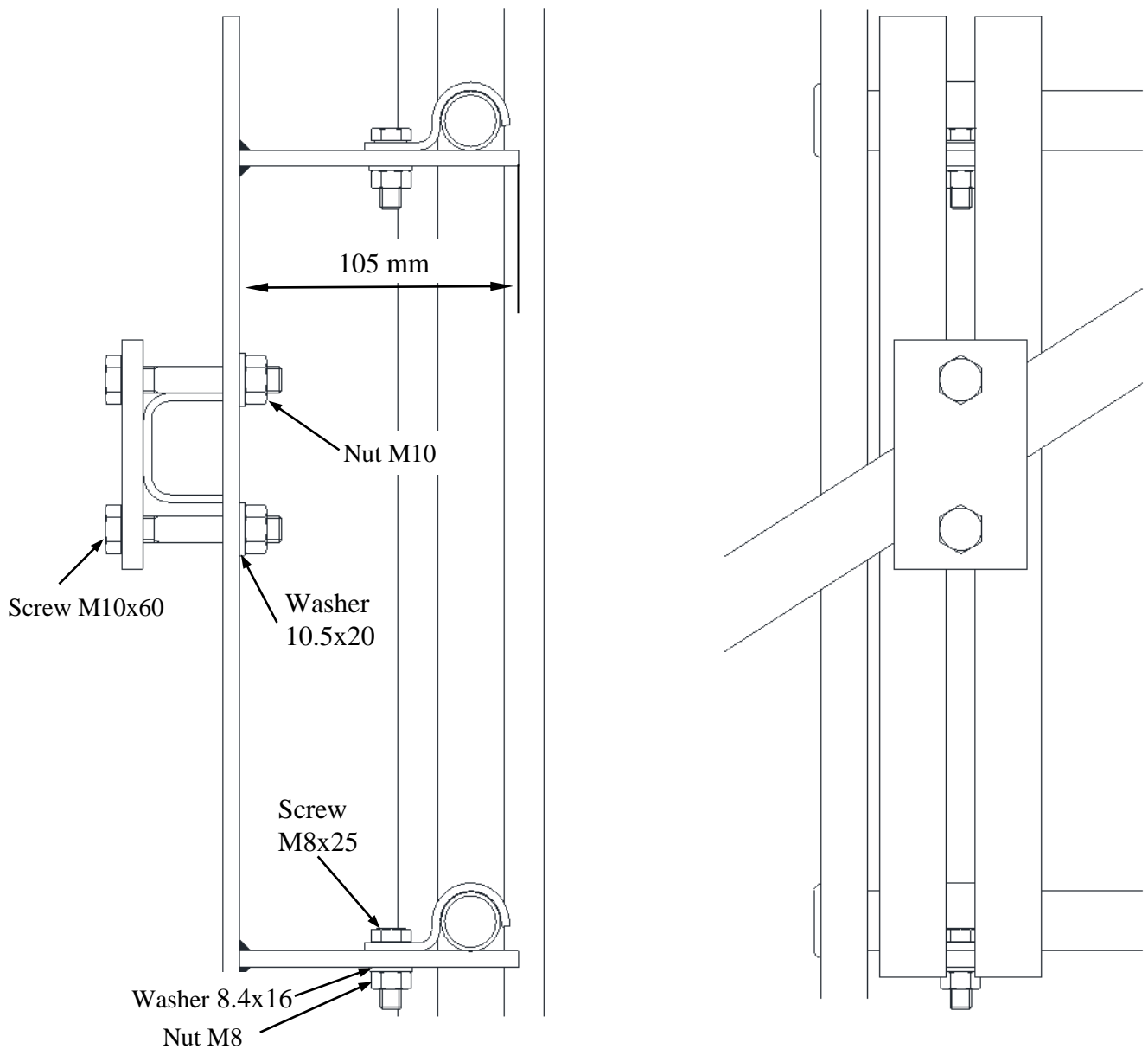

3.3 Ladder bracket 707930

Fits in sections with diagonals larger than 30 mm. Set consisting of 4 x ladder brackets positioned according to picture of respective section.

If cable supports fitted with hooks around the rungs are to be used, the ladder bracket must be fitted 25 mm from the ladder pole.

Assemble the ladder with holes 9 mm in the side profile downwards in the section.

Position the clamp around the rung with accompanying screw in its outermost position (to the right in the left hand picture below) to avoid protruding edges for climbers.

Tighten M10 nut sufficiently without bending the plates.

Then secure all nuts with punch marks.

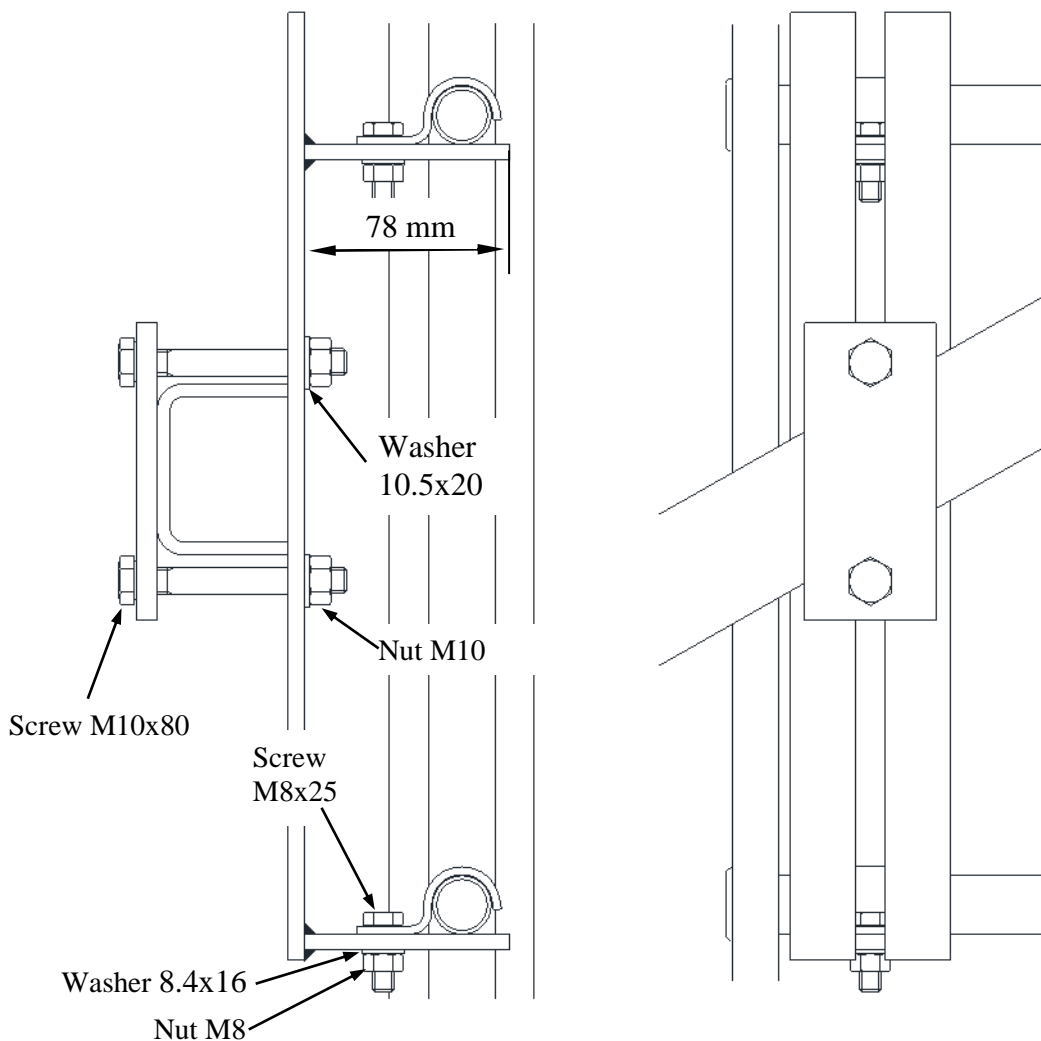

3.4 Cover plate section 20

Secure the nuts with punch marks after tightening.

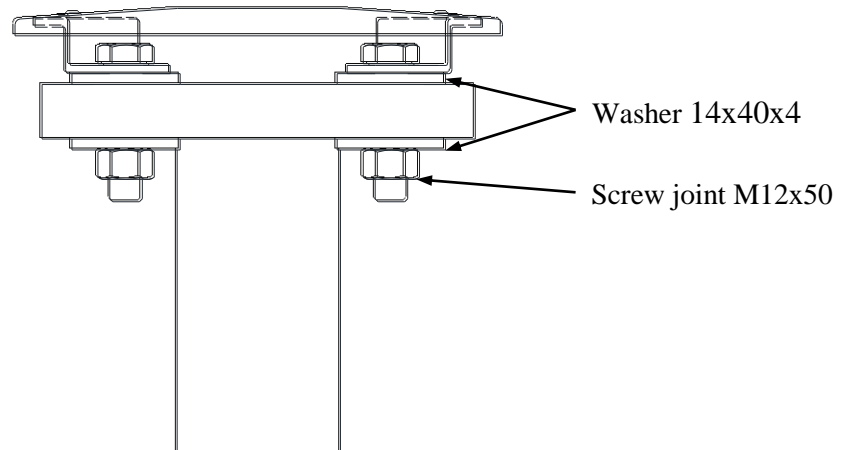

3.5 Ladder joint

Assembly of external ladder joint 708740 requires screws to be fully screwed in. If the tower is erected section by section, ensure that the ladder does not protrude outside the section. If necessary cut the ladder to size. Protect the cut position by cold galvanizing.

External ladder joint

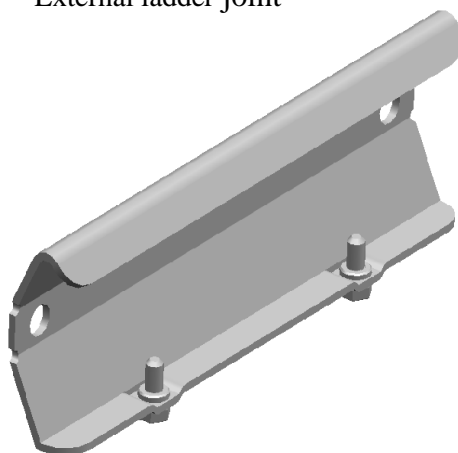

4 ERECTING THE TOWER

4.1 Erecting tower having completely assembled it on the ground

1. Undo the top nut on the foundation bolts. Level the bottom nuts. Place the base plates on the bottom nuts and level the upper surface of the base plates. Ensure that the bottom nuts (the washers) are in close contact with the underside of the base plates. Adjust with the starting-point that the base plates must be as low as possible without any part of them, e.g. the drain pipe, being in contact with the foundation (cf. illustrations chapter 5 "Under casting foundation" in these instructions).
2. Screw on the top nut.
3. Place a lifting strap over the tower's centre of gravity and under a diagonal fixing point

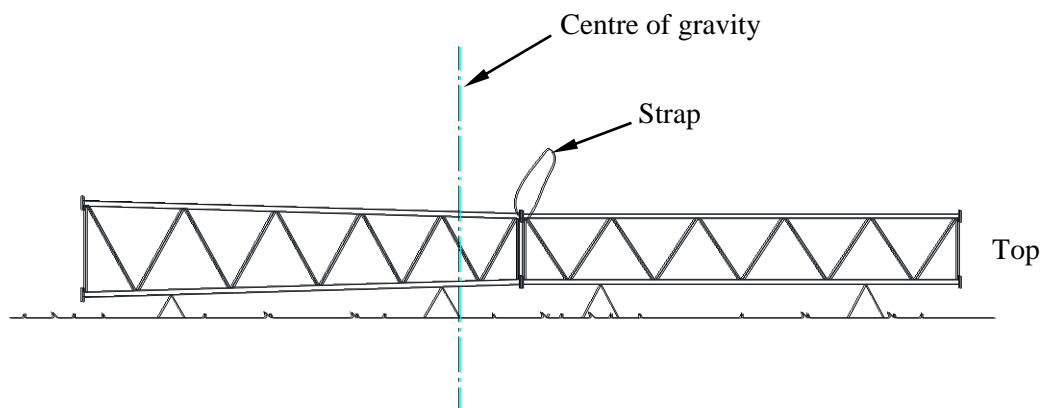

4. Carefully lift the tower with a mobile crane. For masts over 40 m or if the installation engineer is inexperienced, it is recommended that another crane is used to stabilise the bottom end of the tower and prevent it from dragging on the ground
5. Position the tower on the base plates. Screw in the screws between section and base plate and tighten the screws and foundation bolts with torque according to table on page 23.

4.2 Joints between base plates and section 11-17

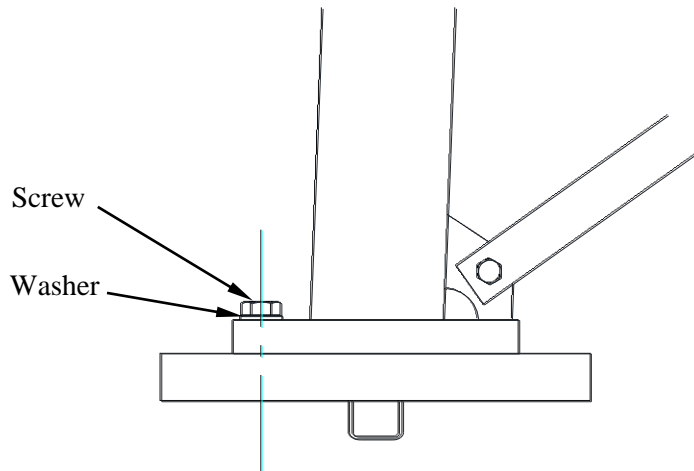

Tighten the screw in the base plates with torque according to the table below.

Section	Part No.	Screw	Torque
111-131	735003	U6S 1UNCx102 galvanized	826 Nm
11-14	715690	M6S 24x100 8.8 galvanized	712 Nm
15	715689	M6S 22x90 8.8 galvanized	554 Nm
16	715688	M6S 22x90 8.8 galvanized	554 Nm
17	715687	M6S 20x80 8.8 galvanized	412 Nm

5. UNDERCASTING BASE PLATES

5.1 Warranty conditions

Once the tower has been erected the base plates must be under cast. Under casting is required for the tower to have full load-carrying capacity and for the warranty to apply. Under casting of base plates is to be done with the mortar specified, for example, BEMIX* expanding frost proof mortar or equivalent.

The under casting must be somewhat smaller in diameter than the base plate so that water cannot collect between mortar and base plate.

*www.finjabemix.se

5.2 Section 11-17

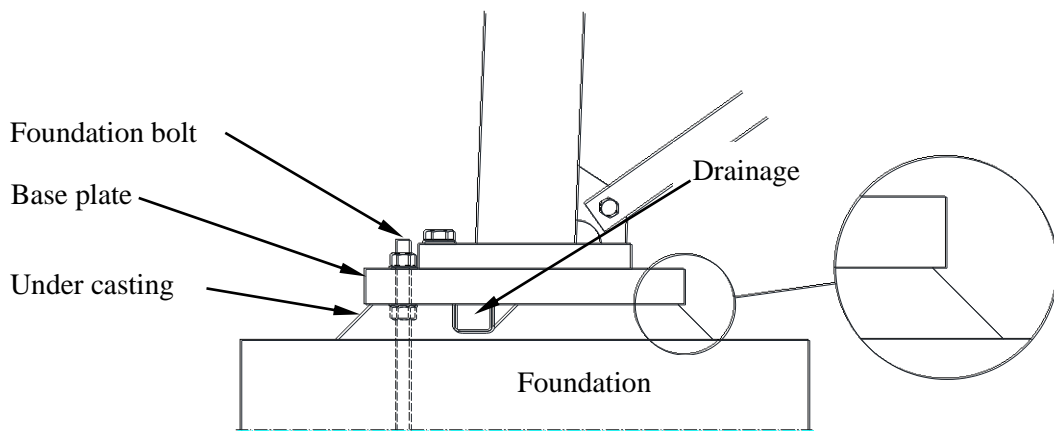

5.3 Section 18-19

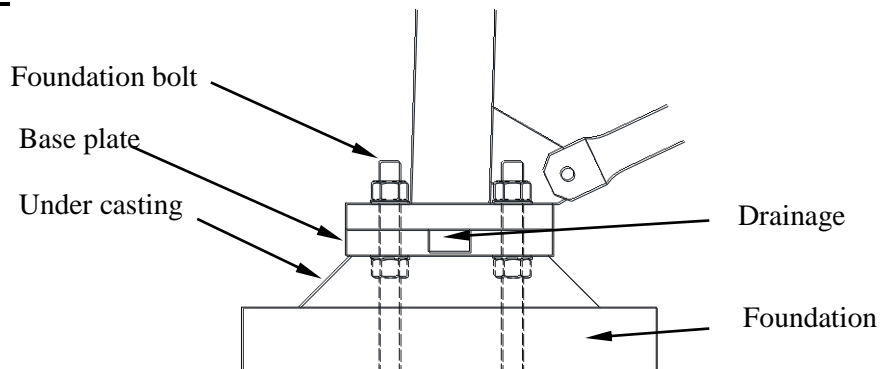

5.4 Section 20

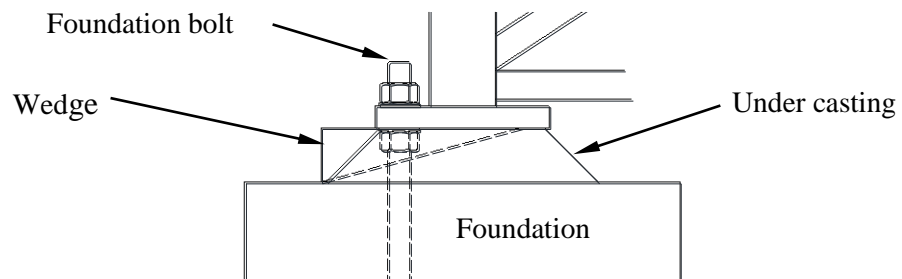

Drainage holes can be created by means of, for example, a styrofoam wedge below the base plate, which is removed once the concrete has hardened. Make sure that drainage is free from dirt.

6. SPECIFICATIONS

6.1 Torque for tightening screw joints (Does not apply to flange joints between sections!)

Tightening torque, torque wrench

Dimension	Lubricant
	Oil
M10	50 Nm
M12	87 Nm
M16	211 Nm
M20	412 Nm
M22	554 Nm
M24	712 Nm
UNC 1"	826 Nm

6.2 Torque for tightening foundation bolts

Tightening torque, torque wrench

Dimension	Lubricant
	Oil
M20	218 Nm
M24	377 Nm
M30	746 Nm

6.3 Locking with punch mark

Joints that are not secured by torqueing must be secured by punch marking nuts according to the figure below.

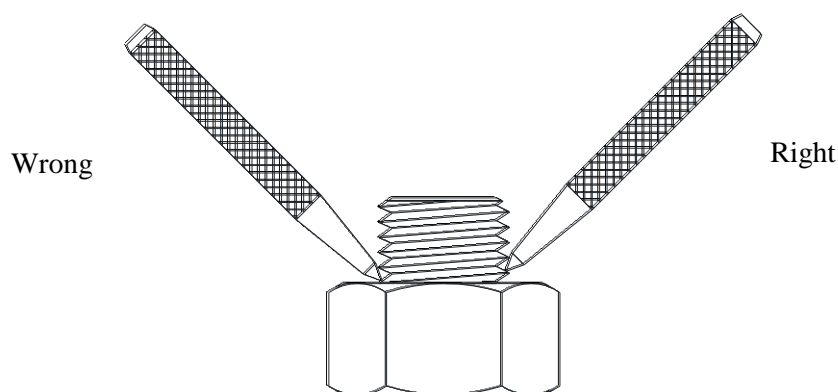

6.4 Weight specifications

Part no.	Description	Weight, kg
100811	Section 11	1100
100822	Section 111	1230
100812	Section 12	1070
100823	Section 121	1200
100813	Section 13	1040
100824	Section 131	1152
100814	Section 14	815
100825	Section 141	885
100815	Section 15	760
100826	Section 151	825
100816	Section 16	595
100827	Section 161	730
100817	Section 17	575
100828	Section 171	680
100818	Section 18	458
100829	Section 181	515
100819	Section 19	295
100830	Section 191	390
100842	Section 193	398
100820	Section 20	240
715690	Base plate 11-14	63
715689	Base plate 15	51
715688	Base plate 16	51
715687	Base plate 17	30
791138	Base plate 18	5.4
791137	Base plate 19	4.8
706413	Ladder	20
707929	Ladder bracket set	8
707930	Ladder bracket set	8
718836	Cover plate set	2
712670	Fixing template 11	153
711497	Fixing template 12	140
711500	Fixing template 13	127
711503	Fixing template 14	113
711514	Fixing template 15	107
715700	Fixing template 16	94
715701	Fixing template 17	81
719785	Fixing template 18	50
711166	Fixing template 19	38
711167	Fixing template 20	28

